

# TAOC Audio Rack ASR II i series

## Instruction Manual

Thank you for purchasing Audio Rack ASR II -NBi/NSi series . Make sure to read these instructions before using and assemble correctly. After reading, keep this manual handy for future reference.



- These audio rack systems are heavy. When assembling and putting, be careful not to get hurt by fall or tumble.
- When assembling audio rack, put curing mat as blanket that can prevent floor from scratch and dent.

### 1. Names and Quantities of Parts (ASR II -3Si is shown in the figure below.)

• Check the quantity referring to the table and figure below.

No.	PART NAME	ASR II-1S	ASR II-2S	ASR II-3S	ASR II-4S	ASR II-5S
①	Shelf frame	1	2	3	4	5
②	shelf board with honeycomb core	1	2	3	4	5
③	pillar(L=180)	0	0	4	8	12
④	pillar(L=230)	0	0	4	4	4
⑤	pillar(L=280)	0	4	0	0	0
⑥	Cap bolt	4	4	4	4	4
⑦	Cast iron Top Cap	4	4	4	4	4
⑧	Cast iron under spacer	0	4	8	12	16
⑨	Bolt	0	4	8	12	16
⑩	Spike for supporting shelf board	4	8	12	16	20
⑪	Cast iron lock nut	4	4	4	4	4
⑫	Cast iron Leg	4	4	4	4	4
⑬	Vibration dumping sheet	2	4	6	8	10
⑭	Hexagonal wrench(small)	1	1	1	1	1
⑮	Hexagonal wrench(large)	1	1	1	1	1
⑯	TAOC LOGO badge	1	1	1	1	1
⑰	Felt sheet	4	4	4	4	4

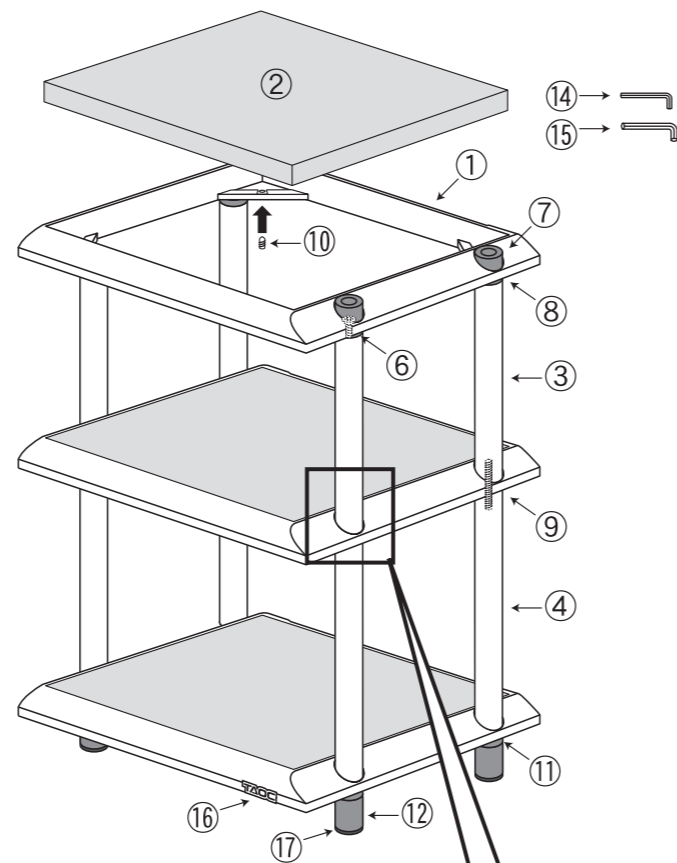

#### <Preparing shelves before assemble>

① Turn all frames over and screw four ⑩spikes every frame with ⑭hexagonal wrench(small) as shown in the figure below.

② Stick ⑬Vibration dumping sheet on two of each shelf along a curve inside of it surely as in the figure 1. Sticking vibration dumping sheets makes reduce frame oscillation properly and improve S/N ratio.

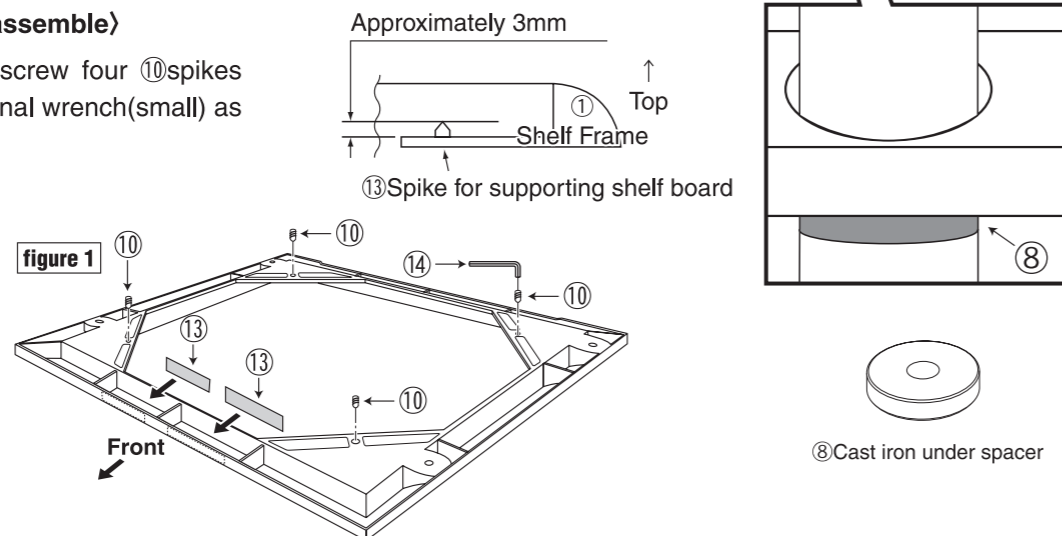

## 2. How to assemble

<Top shelf frame assembly> Combine one step at a time for safety.

- ① Screw ⑨bolts to one side of all pillars in about 2cm.
- ② Put ⑥cap bolts and ⑦cast iron top caps from above as shown in the figure 2. (In ASR II-1S's case, go on step ③.)
- ③ Tighten pillars with them through ⑧cast iron under spacer by using ⑮hexagonal wrench surely as shown in the figure 2. Make sure four pillars and frame are fixed firmly.

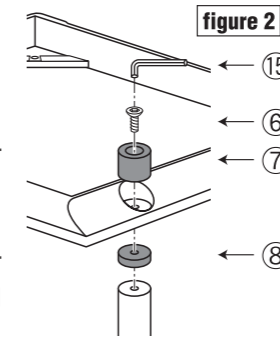

#### <Other shelves assembly>

- ④ Turn top frame assembly over and put it not get scratch.
- ⑤ Put other frame on the pillar with aligning screwing holes from above as shown in the figure 3. (In ASR II-1S's case, go on step ③)
- ⑥ Put ⑧cast iron under spacers on the frame through bolts carefully as shown .
- ⑦ Screw other pillars to bolts on the frame and fix firmly. (Depending on the number of the stage of your rack, repeat step ⑤- ⑦)

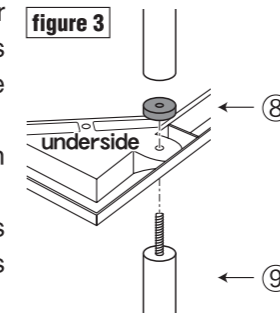

<Legs assembly>

- ⑧ Screw ⑪cast iron lock nuts and ⑫cast iron legs surely and attach ⑰felt sheets on the top of the legs for preventing scratch as shown in the figure 4 mat. Ensure cast iron lock nuts are fixed surely.

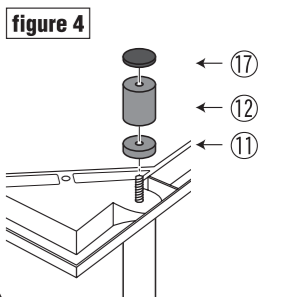

<Adjust stability of rack system>

- ⑨ Turn ASR II i over and set on on the floor carefully. Then remove curing mat.
- ⑩ Stabilize ASR II i rack with adjusting hight of legs by screwing up and down.

<Installing shelf boards and adjusting spikes for supporting them>

- ⑪ Install shelf boards from front carefully. Make sure to do from the bottom stage to top one and don't let it interfere inside of each shelf. (Shelf boards have reversible colored surface. Set the face nearer color to the top for your rack.)
- ⑫ Stabilize the board with adjusting height of spikes up and down from the bottom stage to top one. Then don't let all boards interfere any part of frame. They should be only supported by four spikes at each stage. (If difficult to do, remove all shelf boards once then adjust spikes with lay rack system on the floor with curing mat.)
- ⑬ Stick ⑯TAOC LOGO badge at front of rack system as shown in the figure 5.

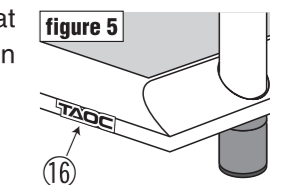

## 3. Caution for using.

- 1.The ASR II i rack series is heavy. Be careful for using.
- 2.Don't set it on the unstable space.
- 3.Don't fall and tumble it.
- 4.Don't move with setting equipments.
- 5.Install audio equipments from bottom stage to top one carefully, or it will may fall, resulting injure.
- 6.Don't use thinner and benzene for surface cleaning. Wipe it carefully with soft cloth.
- 7.Don't use casters with these series other than genuine option as CS-120.

**AISIN TAKAOKA CO., LTD.**

1 Tenno, Takaokahsinmachi, Toyota-city, Aichi Prefecture, Japan, 473-8501  
Telephone;+81-565-54-1272 <http://www.taoc.gr.jp>